



# TERMINATION

**8GHz BNC**

**2Watt**

## Features

- ✓ Frequency Range: DC-8GHz
- ✓ Low VSWR
- ✓ High interface performance



## Specifications

<b>PART NUMBER</b>	MVE5131
<b>DESCRIPTION</b>	BNC Male Termination, 2W DC-8GHz
<b>ELECTRICAL</b>	<b>MATERIALS</b>
FREQUENCY: DC-8GHz IMPEDANCE: 50 OHM POWER RATING: 2 WATTS@25°C VSWR: 1.20 MAX.	BODY: STAINLESS STEEL, PASSIVATED TEMPERATURE: -55°C~+125°C

Tolerance:±0.5mm

## Outline Drawing (Unit: mm)

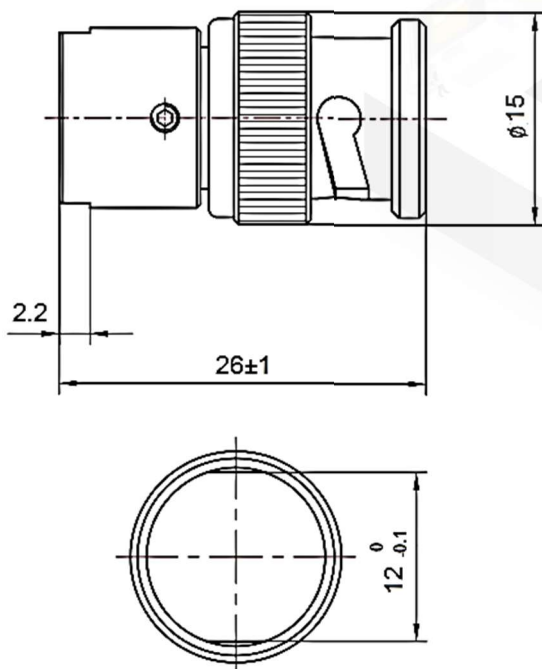

## Typical Test Result

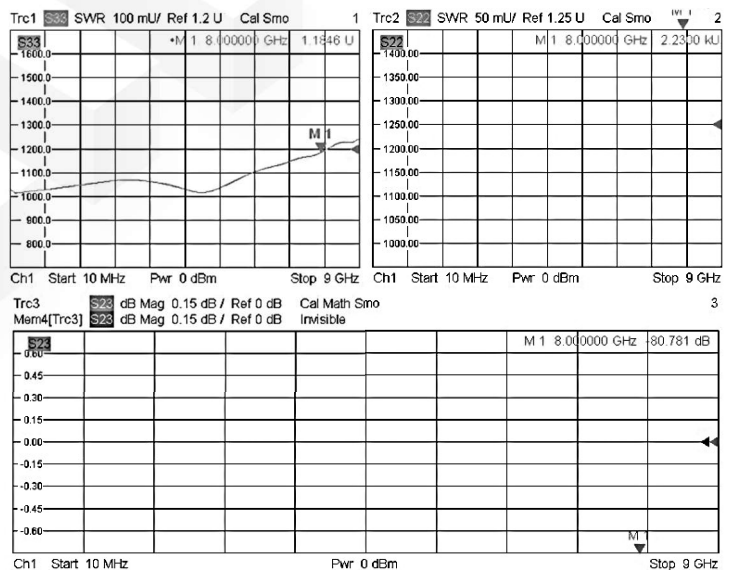

NOTES:

1. ALL SPECIFICATIONS ARE SUBJECT TO CHANGE WITHOUT NOTICE AT ANY TIME
2. CUSTOMER OUTLINE DRAWING FOR REFERENCE ONLY

