



DIRECTIONAL COUPLER

SMA Series
0.5-8GHz

Features

- ✓ Frequency Range: 0.5-8GHz
- ✓ Full Frequency Bandwidth
- ✓ High Directivity



Specifications

FREQUENCY RANGE: 0.5-8GHz
CONNECTOR TYPE: SMA FEMALE
OPERATIONAL TEMPERATURE: -40°C TO +80°C
STORAGE TEMPERATURE: -55°C TO +85°C

PART NUMBER	FREQUENCY	NOMINAL COUPLING	COUPLING SENSITIVITY	INSERTION LOSS	DIRECTIVITY	VSWR	FORWARD POWER
MVE4732-20	0.5-8GHz	20±1dB	≤±0.8dB	≤0.7dB	≥18dB	≤1.20:1	50W

Tolerance:±0.5mm

Outline Drawing (Unit: mm)

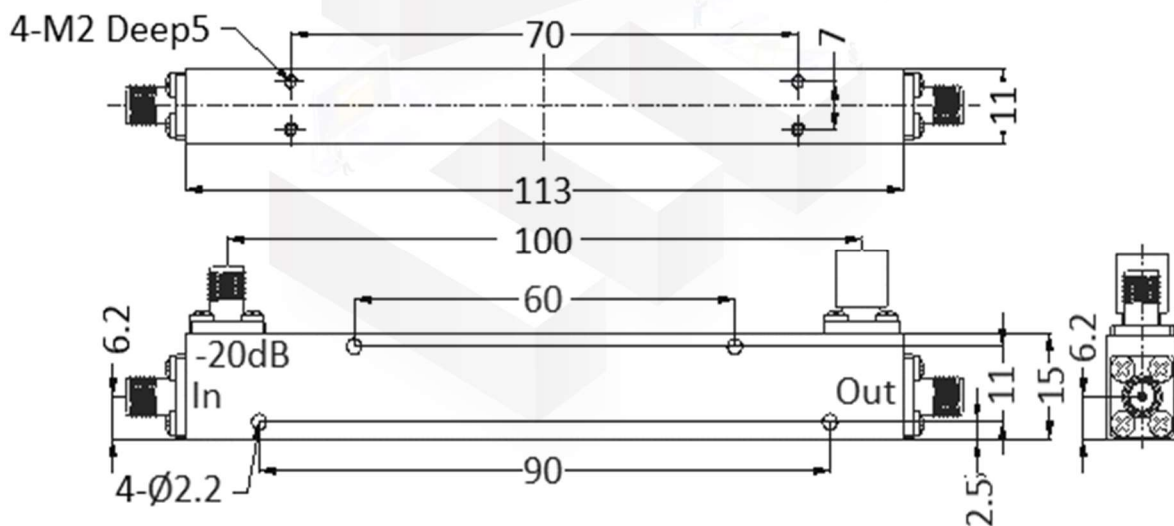

NOTES:
1. ALL SPECIFICATIONS ARE SUBJECT TO CHANGE WITHOUT NOTICE AT ANY TIME
2. CUSTOMER OUTLINE DRAWING FOR REFERENCE ONLY





Typical Test Result

Insertion Loss



Coupling Flatness VSWR

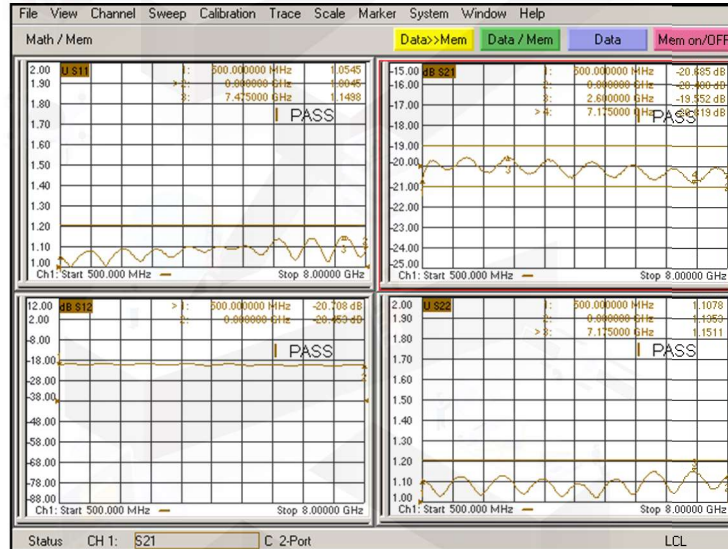

Directivity

