



DIRECTIONAL COUPLER

0.5-6GHz
SMA Series

Features

- ✓ Full Frequency Bandwidth
- ✓ High Directivity
- ✓ Low VSWR



Specifications

FREQUENCY RANGE: 0.5-6GHz
CONNECTOR TYPE: SMA FEMALE
TEMPERATURE RANGE: -30°C TO +70°C

PART NUMBER	COUPLING FACTOR	INSERTION LOSS (MAX.)	DIRECTIVITY (MIN.)	COUPLING SENSITIVITY	VSWR (MAX.)	POWER HANDLING
MVE4513-20	20±1.5dB	1.0dB*	12dB	±1.0dB	1.4:1@Mainline 1.5:1@Coupled	10W

*Excluding Coupling Loss 0.04dB.

Tolerance: ±0.25mm

Outline Drawing (Unit: mm)

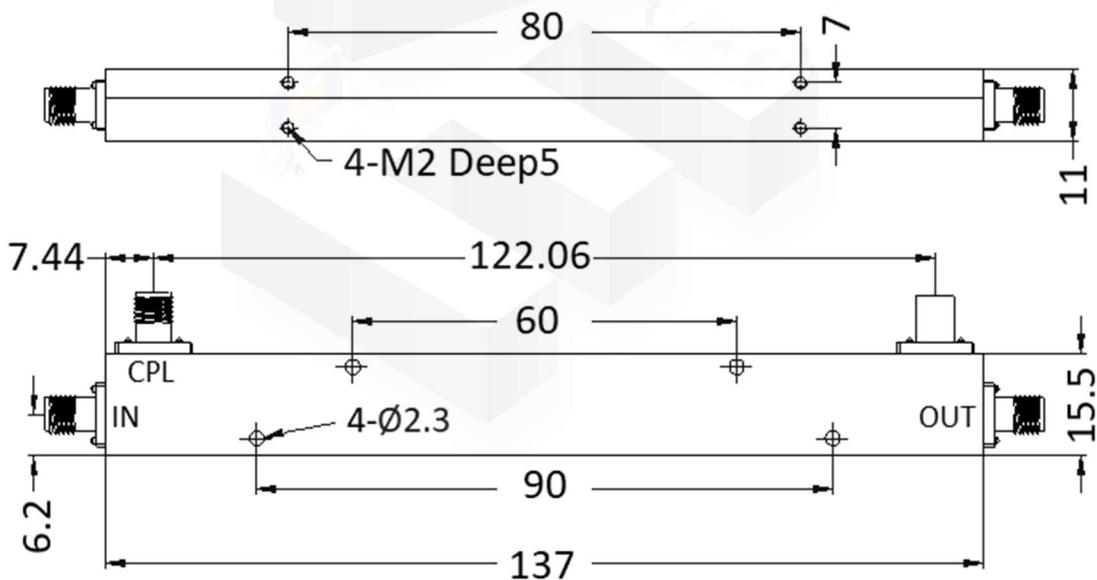

NOTES:
1. ALL SPECIFICATIONS ARE SUBJECT TO CHANGE WITHOUT NOTICE AT ANY TIME
2. CUSTOMER OUTLINE DRAWING FOR REFERENCE ONLY





Typical Test Result

