



FIXED ATTENUATOR MVE2211H-XX

**SMA 2W
DC to 8GHz**

Features

- ✓ Frequency Range: DC to 8GHz
- ✓ High Accuracy
- ✓ Apply to Wi-Fi 6 testing



Specifications

PART NUMBER	IMPEDANCE	FREQUENCY	STANDARD VALUE	VSWR	AVERAGE POWER	CONNECTOR TYPE
MVE2211H-XX	50 ohms	DC - 8GHz	1,2,3,5,6, 10,20,30,40,50	1.25:1	2Watts @25°C	SMA

-XX: Insert dB value desired

ATTENUATION ACCURACY

- 1-10dB: ±0.6dB MAX.
- 11-20dB: ±0.6dB MAX.
- 30dB: ±0.75dB MAX.
- 40dB: ±1.0dB MAX.
- 50dB: ±1.2dB MAX.
- 60dB: ±1.4dB MAX.

MATERIAL/FINISH

BODY: STAINLESS STEEL, PASSIVATED

ENVIRONMENTAL

TEMPERATURE RANGE: -55°C TO +125°C

Tolerance: ±1mm

Outline Drawing (Unit: mm)

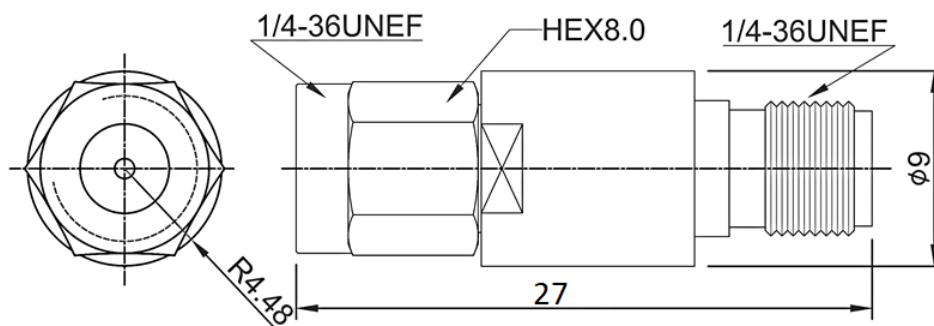

Note 1.

- From 1dB to 30dB, length is 27±1mm
- From 40dB to 60dB, length is 30±1mm

NOTES:
1. ALL SPECIFICATIONS ARE SUBJECT TO CHANGE WITHOUT NOTICE AT ANY TIME
2. CUSTOMER OUTLINE DRAWING FOR REFERENCE ONLY





Typical Test Result

(MVE2211H-02)

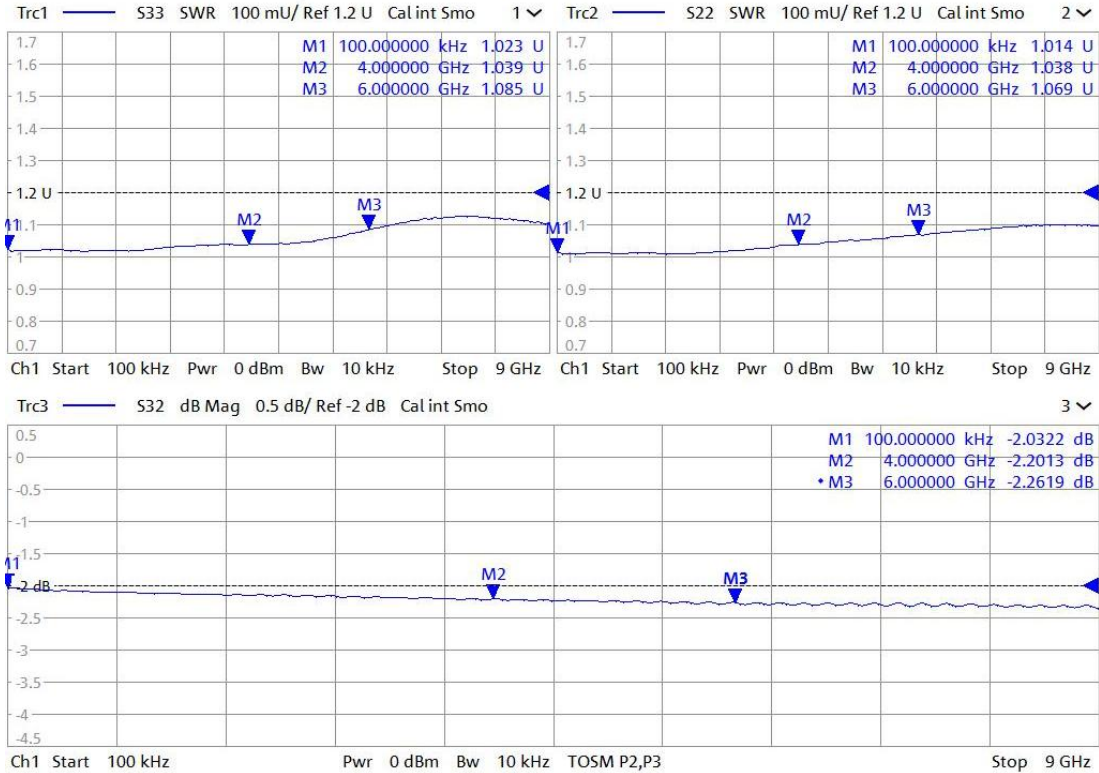

(MVE2211H-03)

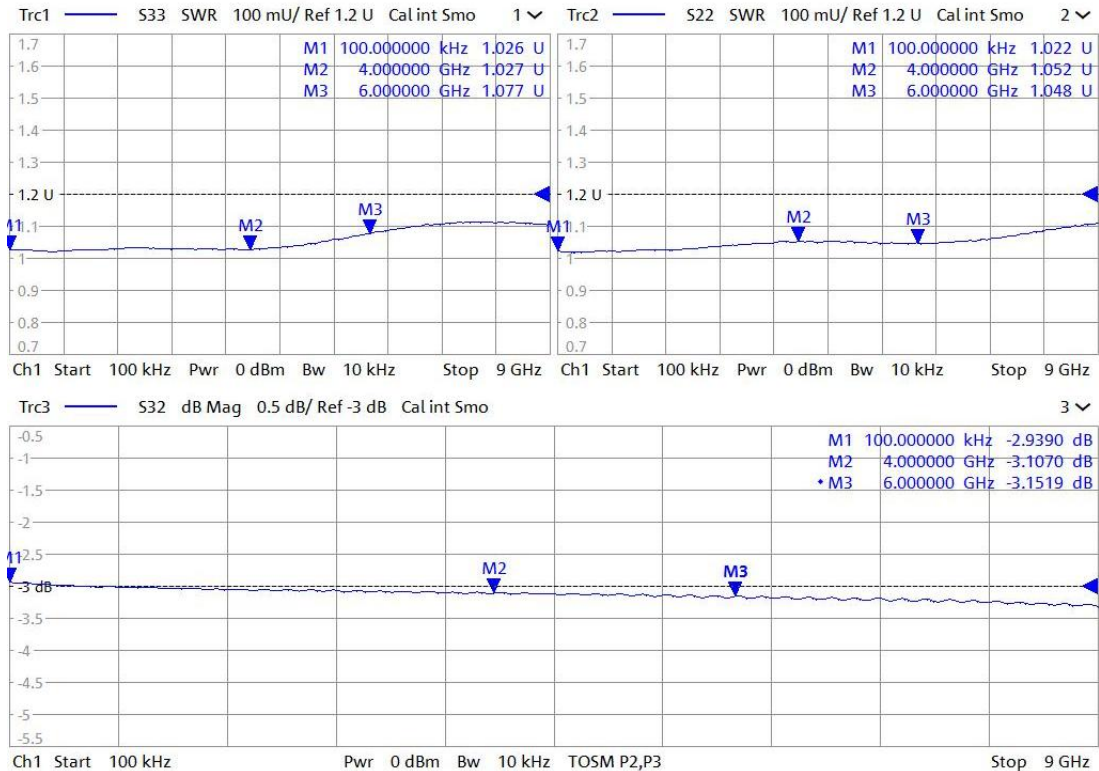



(MVE2211H-05)

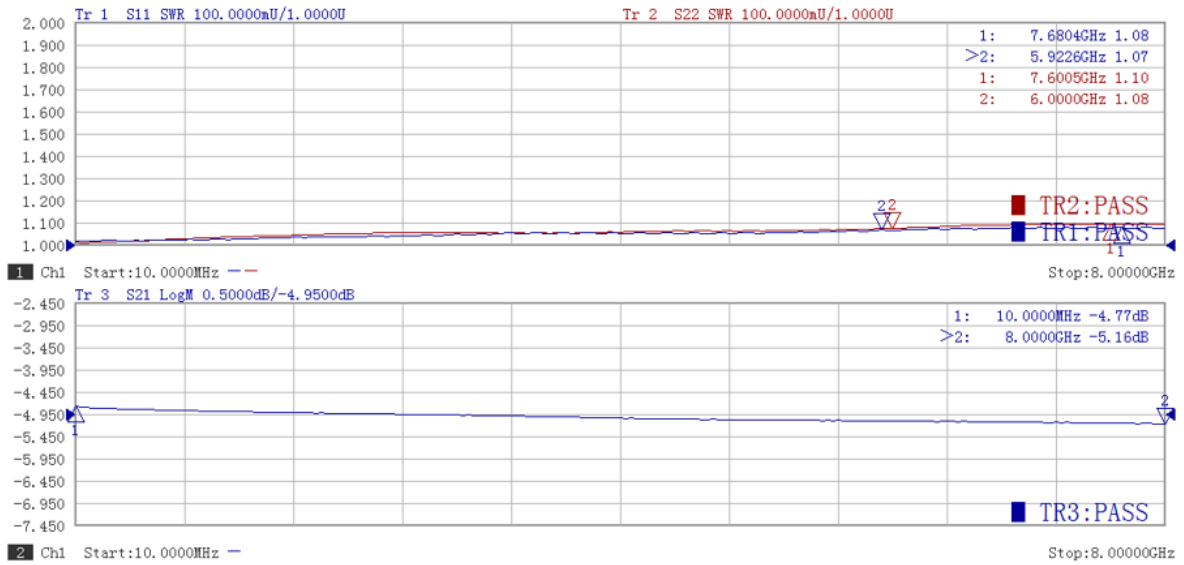

(MVE2211H-10)

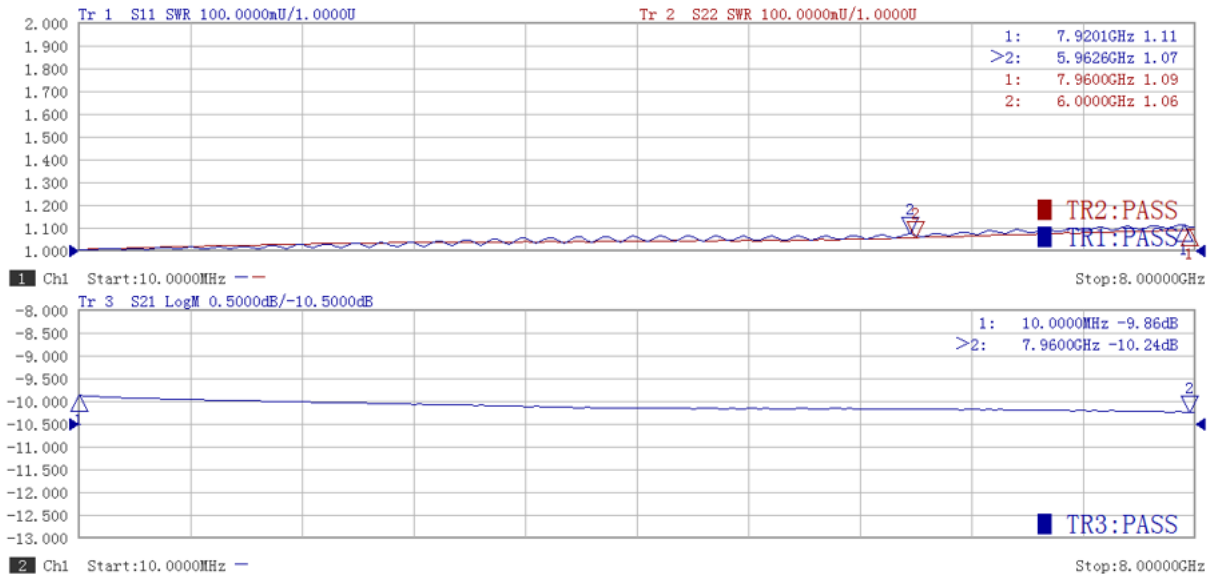



(MVE2211H-20)

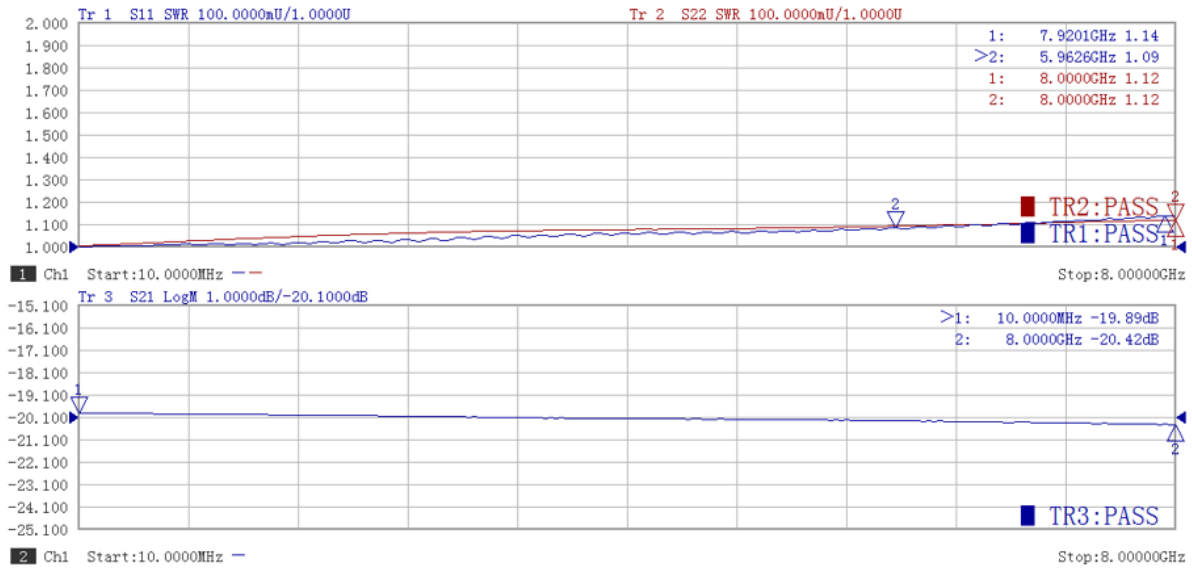

(MVE2211H-30)

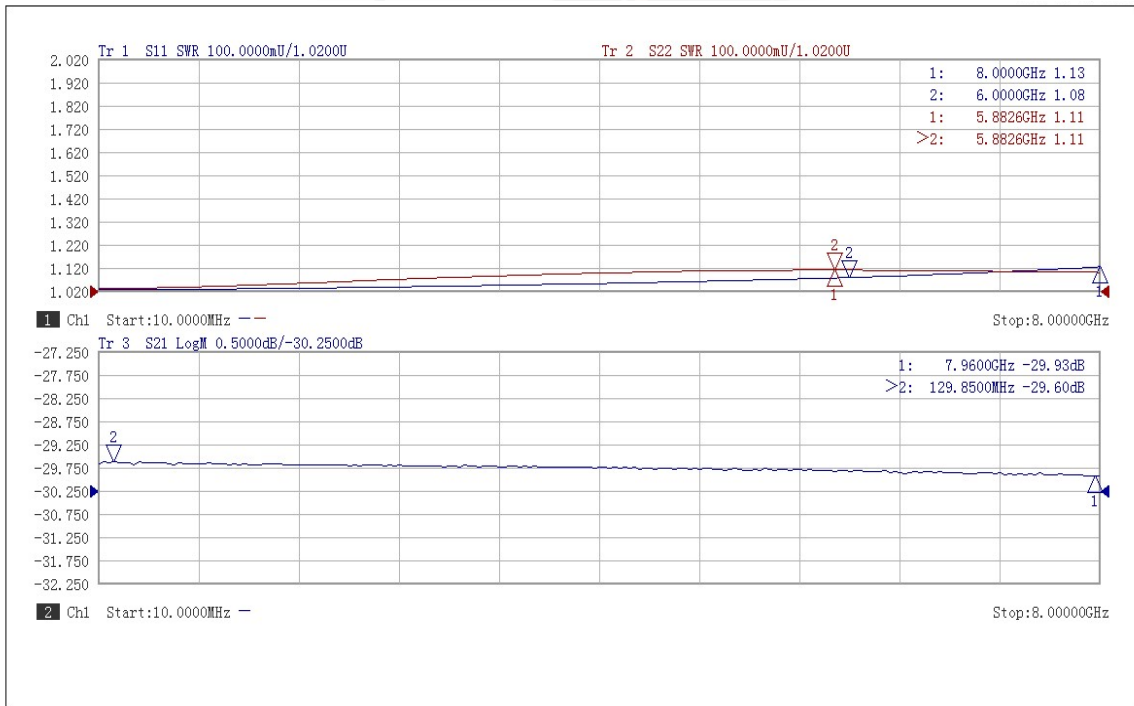



(MVE2211H-40)

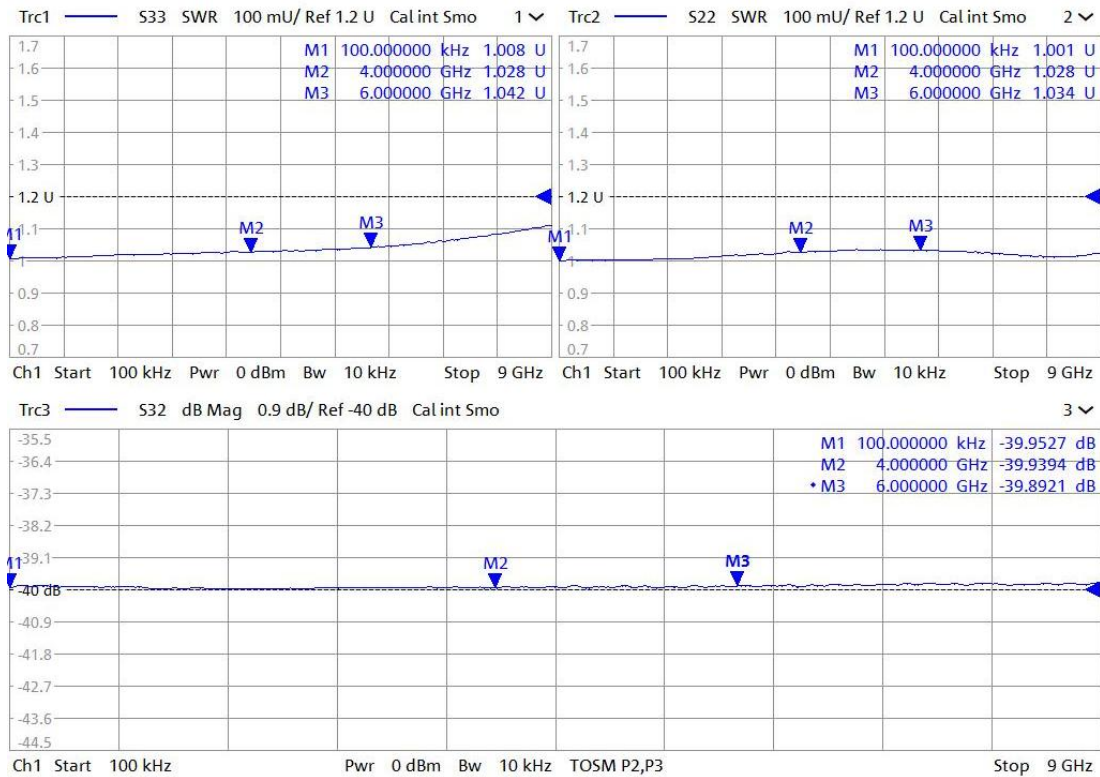

(MVE2211H-50)

