



ABSORPTIVE SWITCH MVE9220

Solid-State, SPDT

Features

- ✓ Wide Band Operation 5-8GHz
- ✓ Impedance :50ohm
- ✓ TTL Compatible driver include
- ✓ Low Insertion Loss / High Isolation

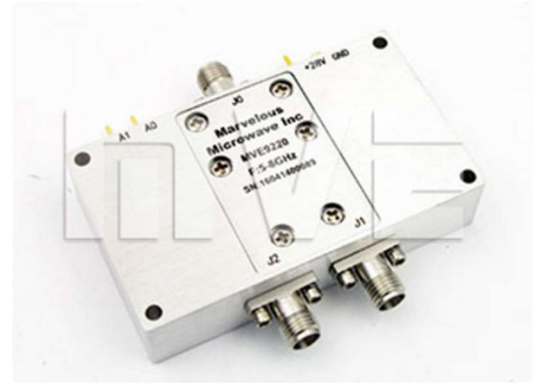

SPECIFICATIONS

PARAMETERS	MINIMUM	TYPICAL	MAXIMUM
FREQUENCY RANGE		5-8GHz	
VSWR		1.4:1	1.8:1
INSERTION LOSS MAX.		1.2dB	1.5dB
ISOLATION MIN.	65dB	75dB	
RF INPUT POWER (CW)			30dBm
DC POWER DISSIPATION (CW)		3W	
0.1 dB Compression P0.1dB		30 dBm	
IIP3		55 dBm	
SWITCHING SPEED		60 ns	100 ns
BIASING (+28V)			150 mA
OPERATIONAL TEMPERATURE	-40°C		+85°C
STORAGE TEMPERATURE	-50°C		+105°C
ALTITUDE	30,000 ft. (Epoxy Seal Controlled environment)		
(OPTIONAL)	60,000 ft. 1.0psi min (Hermetically Seal Uncontrolled environment)		
VIBRATION	25g rms (15 degree 2KHz) endurance, 1 hour per axis		
HUMIDITY	100% RH at 35c, 95% RH at 40°C		
SHOCK	20G for 11msc half sin wave, 3 axis both directions		
CONNECTORS	SMA Female		
MATERIAL / FINISHING	Aluminum / Chromate Finish Aluminum		



Tolerance:±0.3mm

OUTLINE DRAWING: (mm)

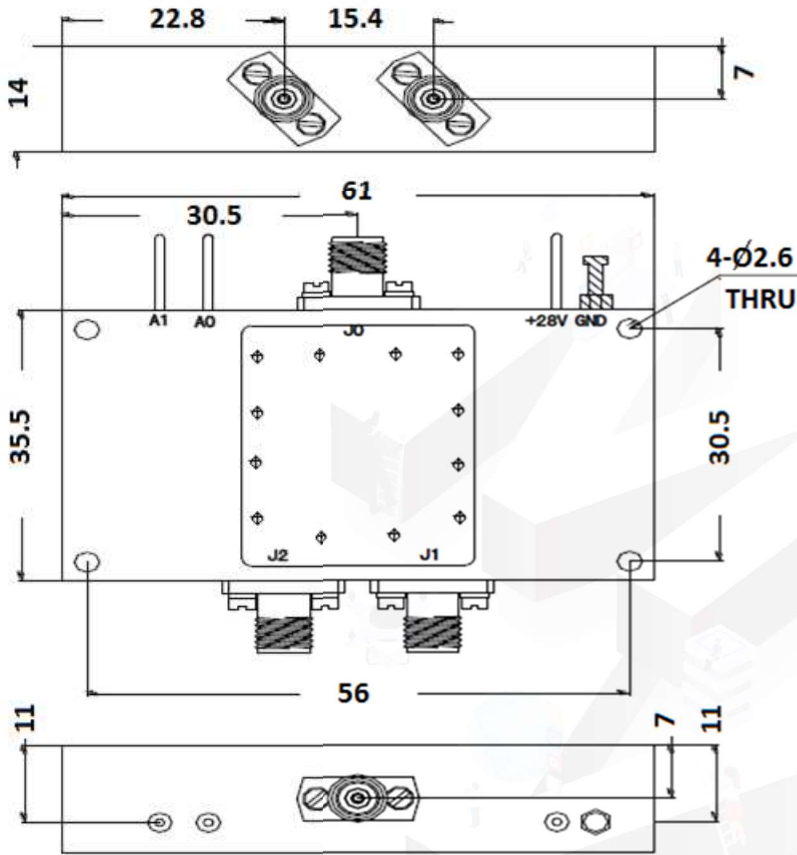

TRUTH TABLE		
Control	Input	Signal Path State
TTL		
AO	A1	
0	1	J0-J1
1	0	J0-J2
Control Pin Customization available upon request		

Absolute Max. Ratings	Design to meet the Spec.
Biasing	+28V±10%
TTL Control Voltage	0-0.8V/2.8-5V
Operating Temp.	-40°C~+85°C
Storage Temp.	-50°C~+105°C



Typical Test Result

Insertion loss@+25°C

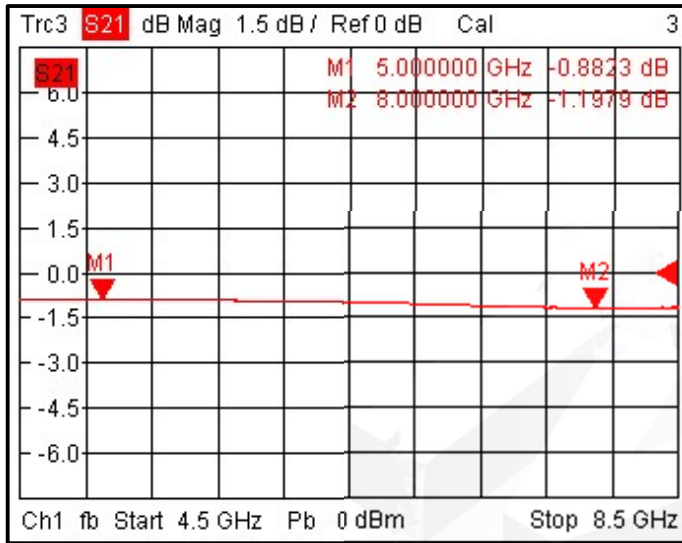

Input VSWR@+25°C

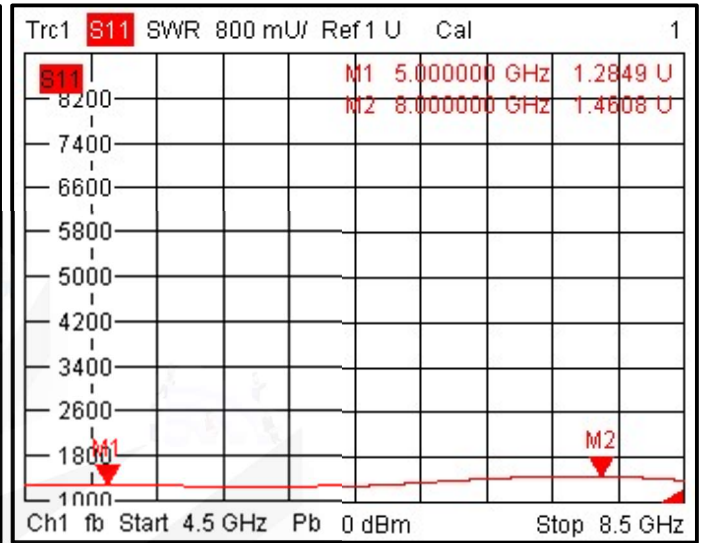

Output VSWR@+25°C

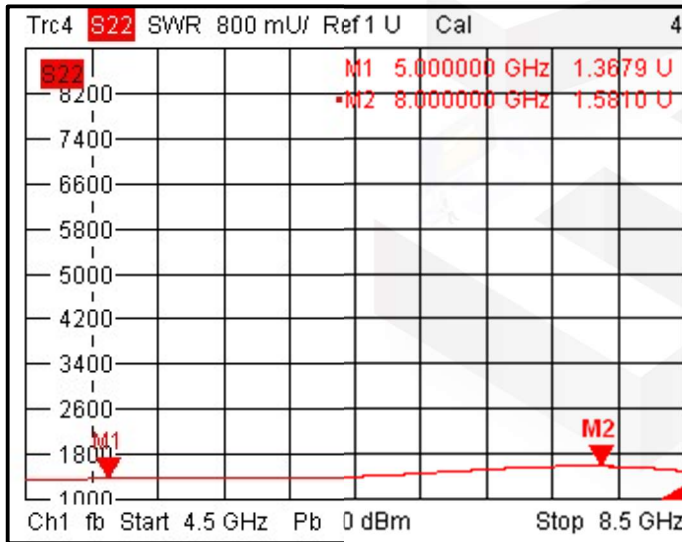

Isolation@+25°C

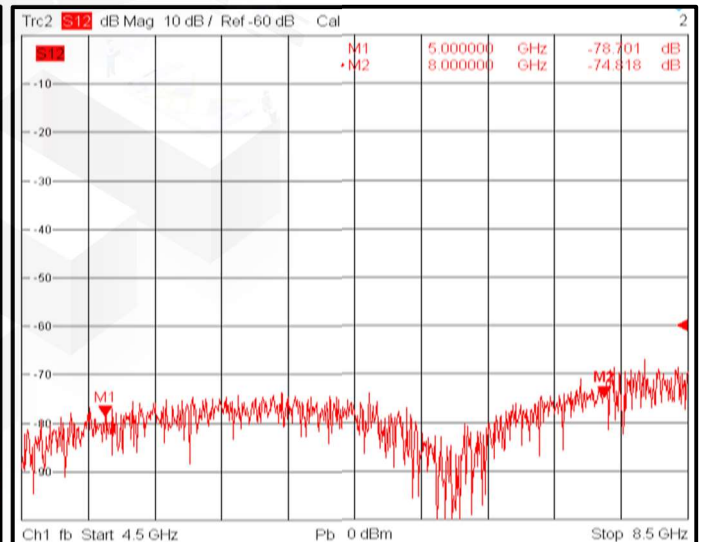

NOTES:

1. ALL SPECIFICATIONS ARE SUBJECT TO CHANGE WITHOUT NOTICE AT ANY TIME
2. CUSTOMER OUTLINE DRAWING FOR REFERENCE ONLY