

ELECTRICAL DATA

FREQUENCY : DC-9GHz

IMPEDANCE: 50Ω

VSWR: 1.3:1MAX. (DC-6GHz)/ 1.5:1 TYP.(9GHz)

INSULATION RESISTANCE: 1000 Mega-Ohms

DIELECTRIC WITHSTANDING VOLTAGE: 500Vrms

INSERTION LOSS: 6GHz > -0.2dB

MECHANICAL DATA

COUPLING METHOD: THREADED

TEMPERATURE RANGE: -65~165°C

DURABILITY: 10000 CYCLES MIN.

APPLICATION

Fully mating with Hirose U.FL , IPEX MHF.

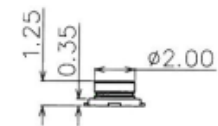
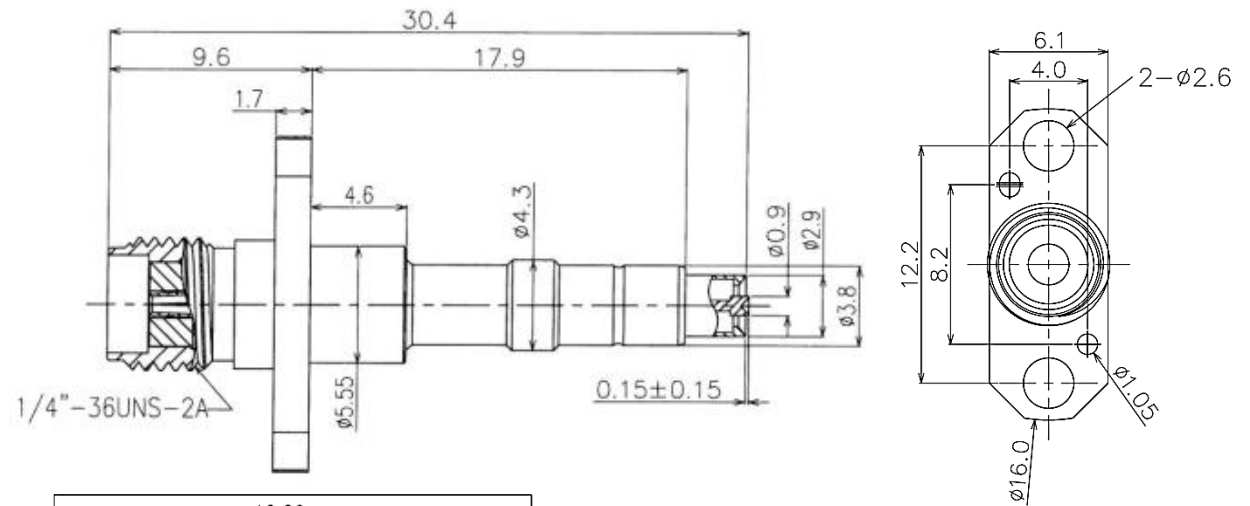

APPLICATION
THE VIEW 2:1

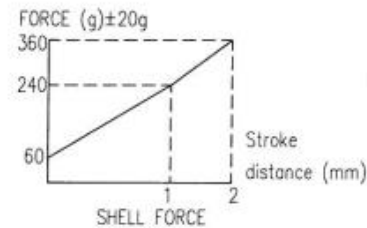
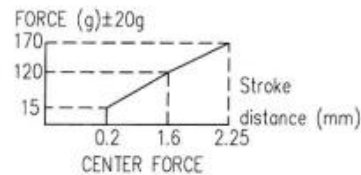
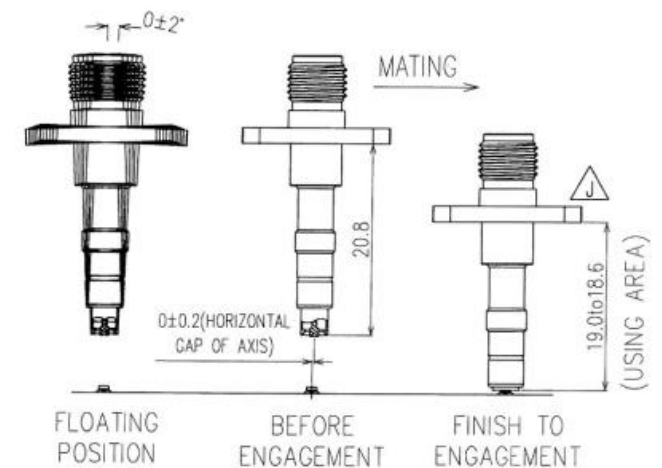
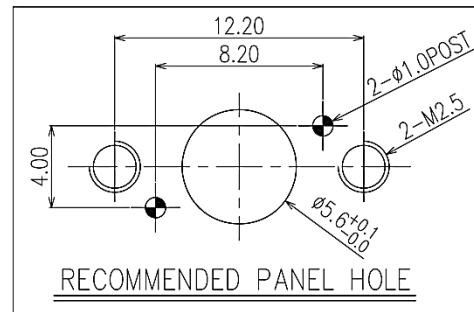

DESCRIPTION	MATERIALS	ROHS COMPLIANCE	UNIT: mm
BODY	BRASS/BE CU, GOLD PLATED	TOLERANCE: X=±0.38 X.X=±0.25 X.XX=±0.15	
CENTER CONTACT	PH BR/STEEL, GOLD PLATED	TITLE	
SPRING	STAINLESS SUS304, GOLD PLATED	U.FL/MHF To SMA Female 2 Hole Probe Adapter, DC-9GHz(positioning hole: Ø1.05)	
INSULATOR	TEFLON		

MVE 芝程科技有限公司
www.micro-mve.com

DC-67GHz RF& Microwave Components

PART NO.	MVE1998-30.4D	REV 3.1
SIZE: A	SHEET: 1/1	SCALE:

NOTES

1. ALL SPECIFICATIONS ARE SUBJECT TO CHANGE WITHOUT NOTICE AT ANY TIME
2. CUSTOMER OUTLINE DRAWING FOR REFERENCE ONLY

Typical Test Result

PART NUMBER	DESCRIPTION
MVE1998-30.4D	U.FL/MHF To SMA Female 2 Hole Probe Adapter, DC-9GHz(positioning hole: O1.05)

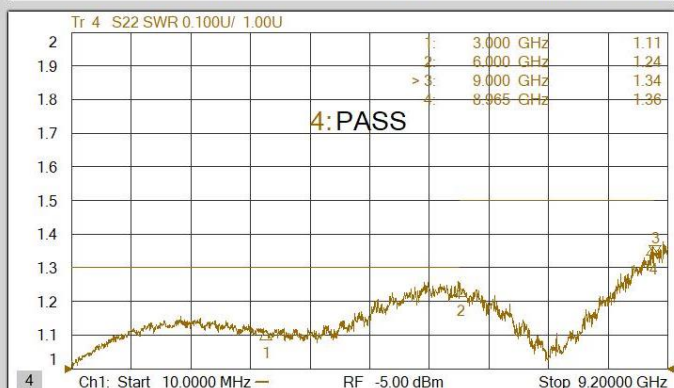
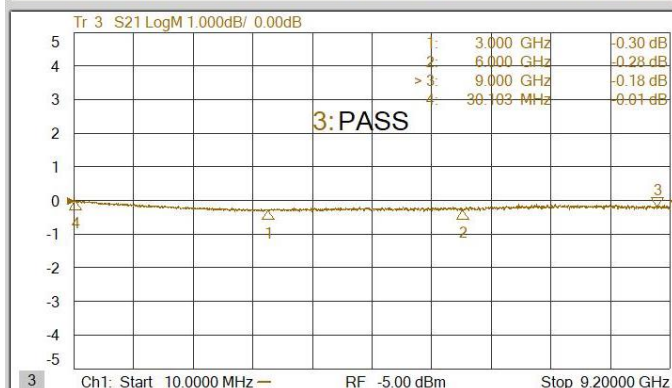
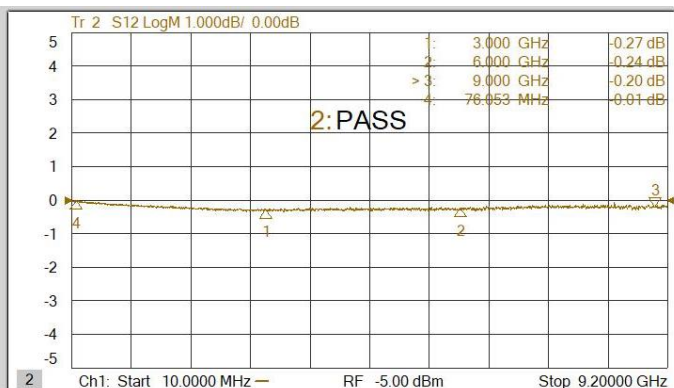

NOTES

1. ALL SPECIFICATIONS ARE SUBJECT TO CHANGE WITHOUT NOTICE AT ANY TIME
2. CUSTOMER OUTLINE DRAWING FOR REFERENCE ONLY