

COAXIAL ADAPTER

SMB-SMA Standard Series

Features

- ✓ Frequency Range: DC to 6GHz
- ✓ SMA-SMB Interface
- ✓ Low VSWR



Specifications

PART NUMBER	MVE1593B
DESCRIPTION	SMA Female To SMB Female Adapter, DC-6GHz
ELECTRICAL	MATERIALS
FREQUENCY: DC-6GHz IMPEDANCE: 50 OHMS VSWR: 1.20:1 MAX. DIELECTRIC WITHSTANDING VOLTAGE: 1000V INSULATION RESISTANCE: 5000MOHM MIN. DURABILITY: 500 CYCLES TEMPERATURE RANGE: -55~+165°C	BODY: BRASS, GOLD PLATED CONDUCTOR: BERYLLIUM BRONZE, GOLD PLATED INSULATOR: PTFE

Tolerance: ±0.5mm

Outline Drawing (Unit: mm)

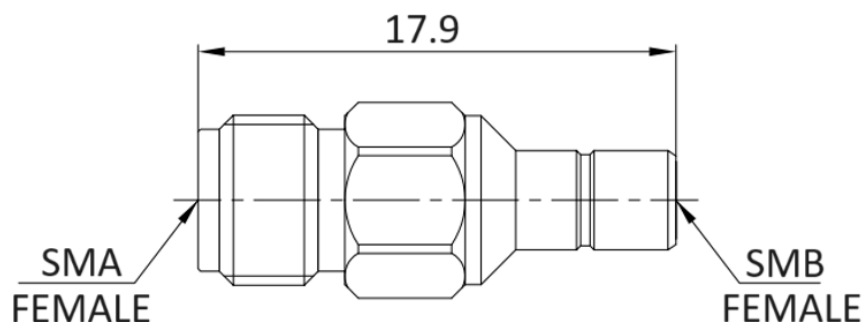

- NOTES:
1. ALL SPECIFICATIONS ARE SUBJECT TO CHANGE WITHOUT NOTICE AT ANY TIME
 2. CUSTOMER OUTLINE DRAWING FOR REFERENCE ONLY



Typical Test Result

PART NUMBER	DESCRIPTION
MVE1593B	SMA Female To SMB Female Adapter, DC-6GHz

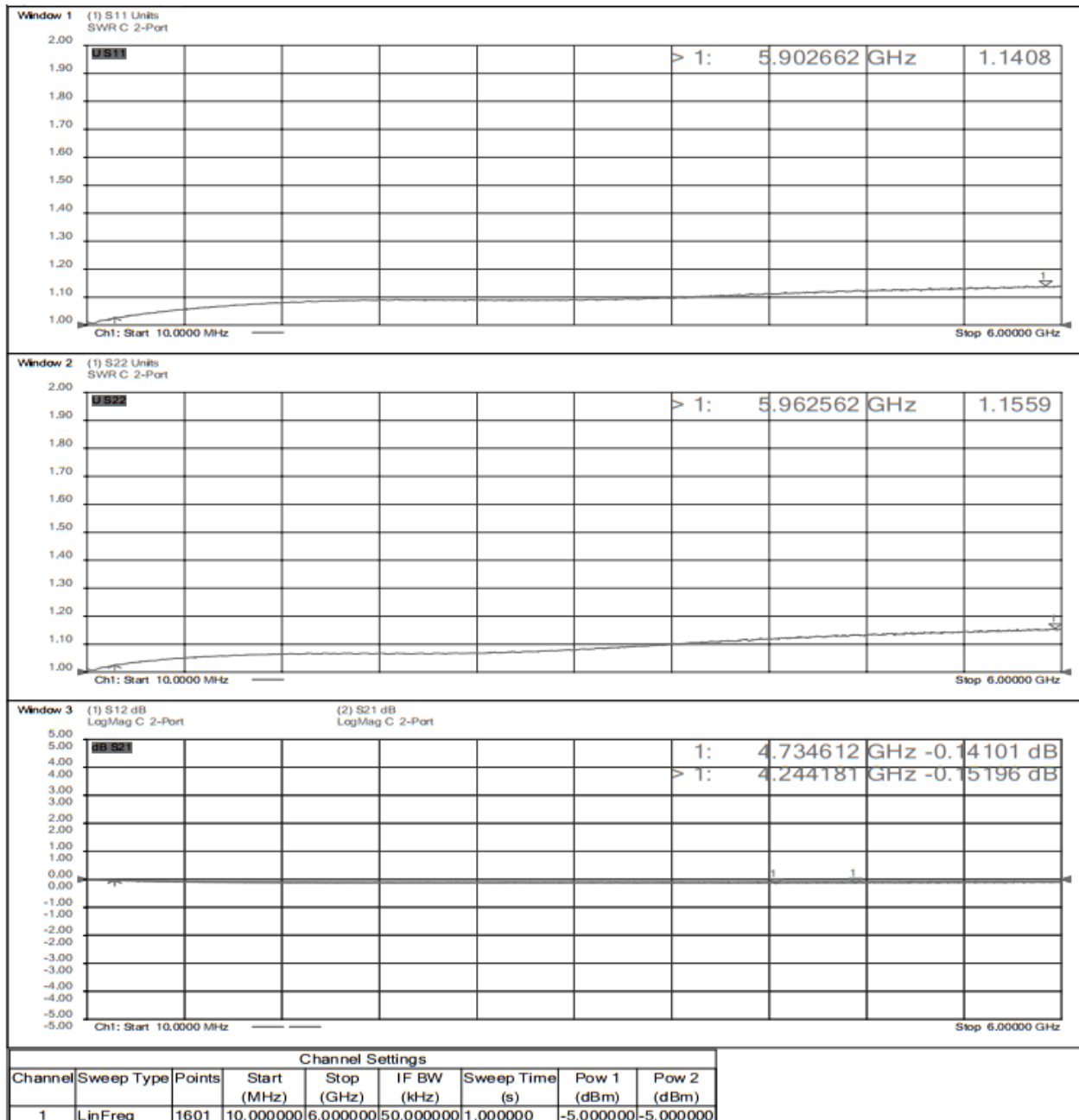

NOTES:

1. ALL SPECIFICATIONS ARE SUBJECT TO CHANGE WITHOUT NOTICE AT ANY TIME
2. CUSTOMER OUTLINE DRAWING FOR REFERENCE ONLY