

ELECTRICAL DATA

FREQUENCY: DC-14GHz

IMPEDANCE: 100Ω

VSWR: 1.60:1@DC-14GHz

INSULATION RESISTANCE: 100Mega-ohms

DIELECTRIC WITHSTANDING: 500Vrms

MECHANICAL DATA

COUPLING METHOD: SLIDE-IN

TEMPERATURE RANGE: -55~165°C

DURABILITY (MATING/UNMATING): 2000 CYCLES

ROHS COMPLIANCE

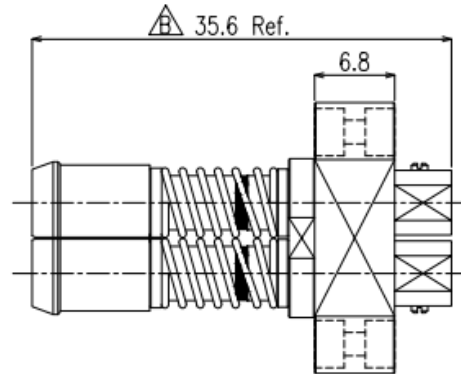
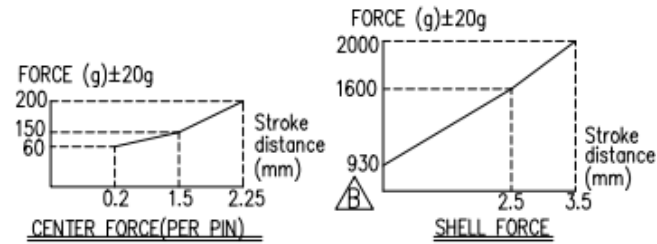
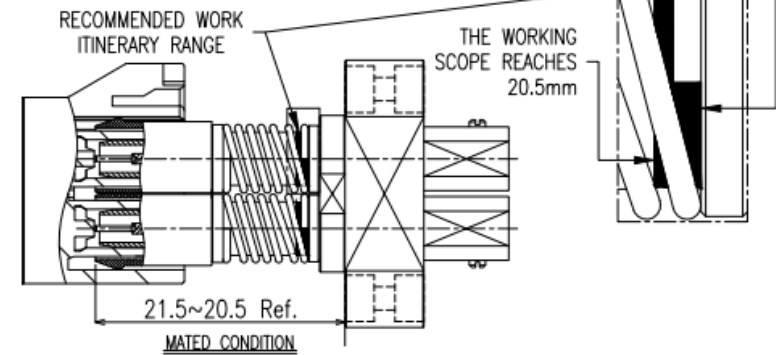
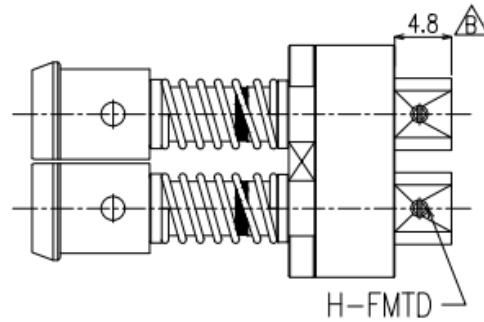
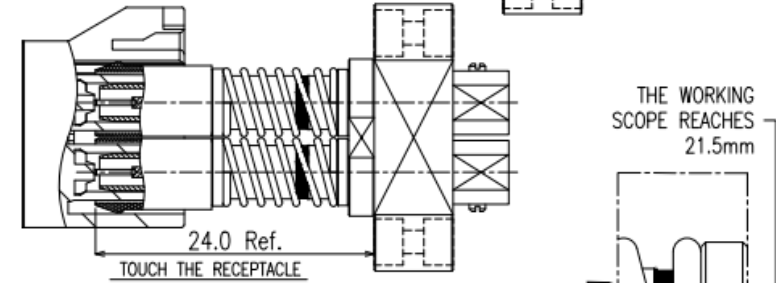
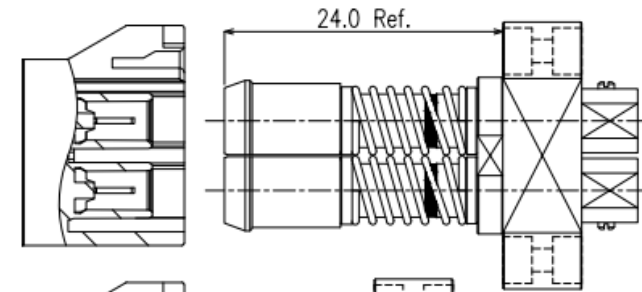
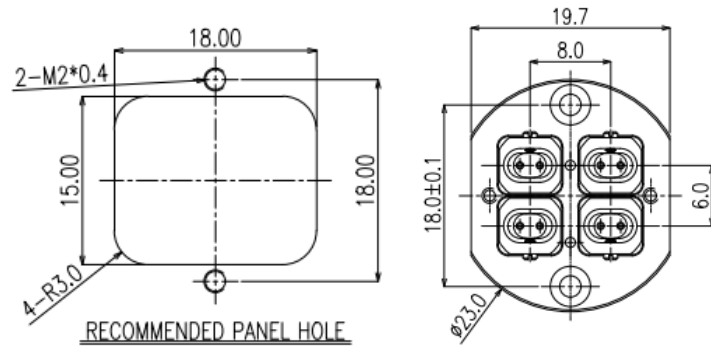

DESCRIPTION	MATERIALS	ROHS COMPLIANCE	UNIT: mm
SHELL BODY	ALUMINUM ALLOY	TOLERANCE: X=±0.38 X.X=±0.25 X.XX=±0.15	
BODY/SCREW	BRASS/STEEL,NICKEL/GOLD	TITLE H-FMTD Floating Coaxial Probe(4 Ports 2X2)	
CENTER CONTACT	BRASS/BE-CU,GOLD		
INSULATOR	TEFLON		
SPRING	SUS304		

MVE 芝程科技有限公司
www.micro-mve.com

DC-67GHz RF& Microwave Components

PART NO.	MAP-H401	REV	1.1
SIZE: A	SHEET: 1/1	SCALE:	

NOTES

1. ALL SPECIFICATIONS ARE SUBJECT TO CHANGE WITHOUT NOTICE AT ANY TIME
2. CUSTOMER OUTLINE DRAWING FOR REFERENCE ONLY