

WRENCH-N-13(20)

N TYPE
1.35N.m



PART NUMBER	FOR SERIES	TORQUE	OPEN SIZE	ACCURACY	NOTE
WRENCH-N-13(20)	N Type	1.35N.m	20 mm	±6%	Adjustable

Tolerance: ±0.36mm

Outline Drawing (Unit: mm)

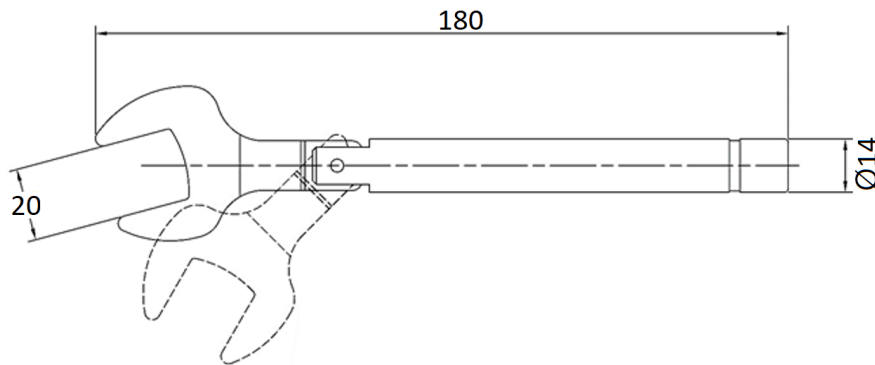

Typical Test Result

Detection torque value (N.m)	Measured value (N.m)
1.35	1.342

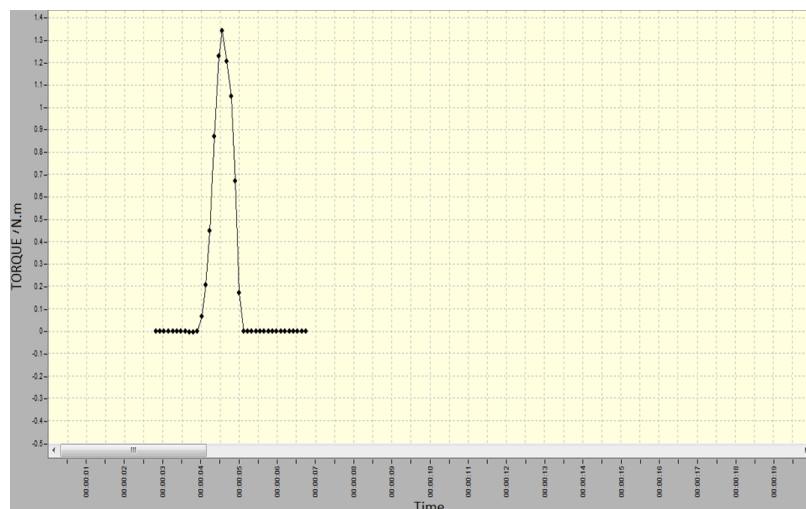

NOTES:
1. ALL SPECIFICATIONS ARE SUBJECT TO CHANGE WITHOUT NOTICE AT ANY TIME
2. CUSTOMER OUTLINE DRAWING FOR REFERENCE ONLY

