

WRENCH-N-12(19)

N TYPE
1.35N.m

PART NUMBER	FOR SERIES	TORQUE	OPEN SIZE	ACCURACY	NOTE
WRENCH-N-12(19)	N Type	12in-lbs/1.35N.m	19 mm	±6%	Adjustable

Outline Drawing (Unit: mm)

Tolerance:+0.3mm

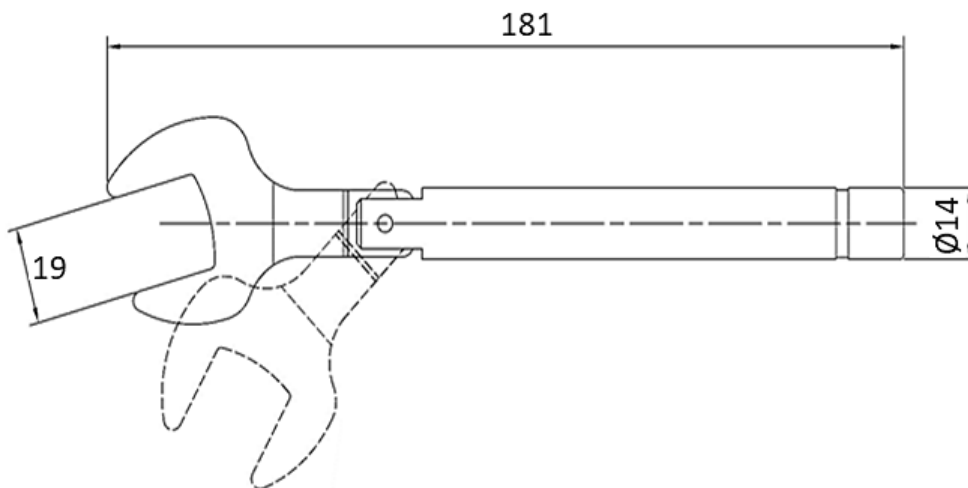

NOTES:
1. ALL SPECIFICATIONS ARE SUBJECT TO CHANGE WITHOUT NOTICE AT ANY TIME
2. CUSTOMER OUTLINE DRAWING FOR REFERENCE ONLY