

ELECTRICAL DATA

FREQUENCY : DC-8GHz

IMPEDANCE: 50Ω

VSWR:1.5:1 MAX. (DC-8GHz)

INSERTION LOSS: 1 dB MAX.

DIELECTRIC WITHSTANDING VOLTAGE: 500 Vrms

WORKING VOLTAGE: 170 Vrms MAX.

INSULATION RESISTANCE: 1000Mega Ohms

CENTER CONTACT RESISTANCE: 6.0 mini Ohm

OUTER CONTACT RESISTANCE: 2.5 mini Ohm

MECHANICAL DATA

DOUBLT SPRING DESIGN

DURABILITY(MATING/UNMATING):10,000 Cycles

APPLICATION



Fully mating with Hirose U.FL , IPEX MHF.

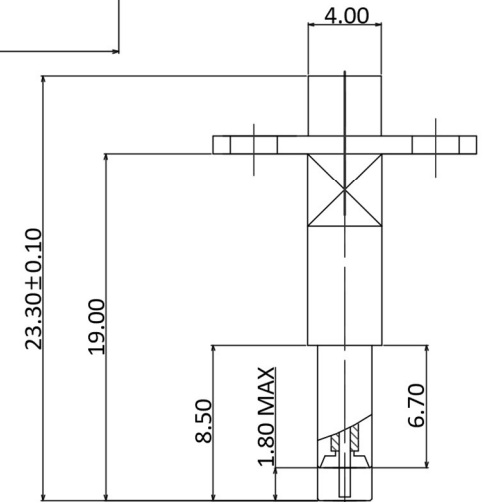
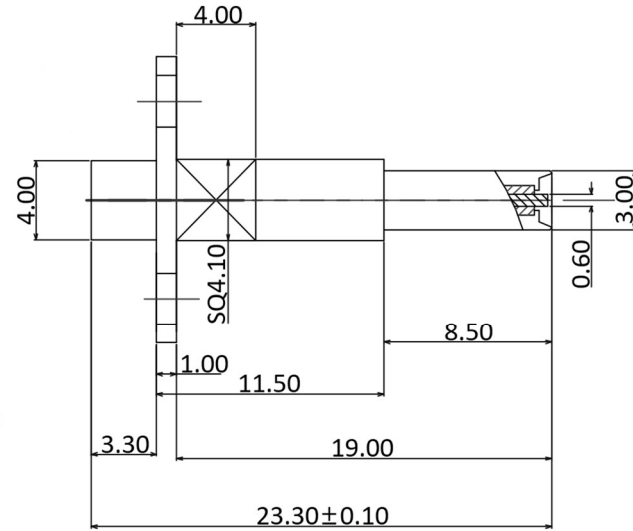
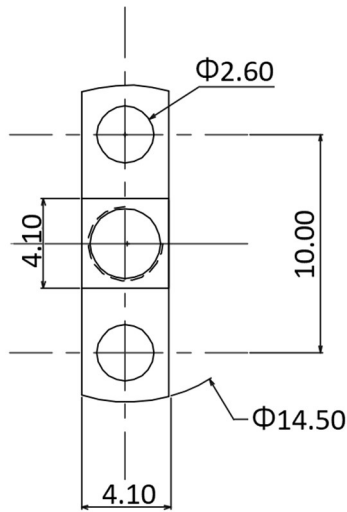

DESCRIPTION	MATERIALS	ROHS COMPLIANCE	UNIT: mm
SPRING	SUS304	TOLERANCE: X=±0.2 X.X=0.01 X.XX=±0.05	
INSULATOR	TEFLON	TITLE	
BODY	TEFLON BRASS,GOLD PLATED	MMCX Female To U.FL Probe Adapter, DC-8GHz	

NOTES

1. ALL SPECIFICATIONS ARE SUBJECT TO CHANGE WITHOUT NOTICE AT ANY TIME
2. CUSTOMER OUTLINE DRAWING FOR REFERENCE ONLY



芝程科技有限公司

www.micro-mve.com

DC-67GHz RF& Microwave Components

PART NO.

MVE1968

REV
2.3

SIZE: A

SHEET: 1/1

SCALE:

Typical Test Result

PART NUMBER	DESCRIPTION
MVE1968	MMCX Female To U.FL Probe Adapter, DC-8GHz

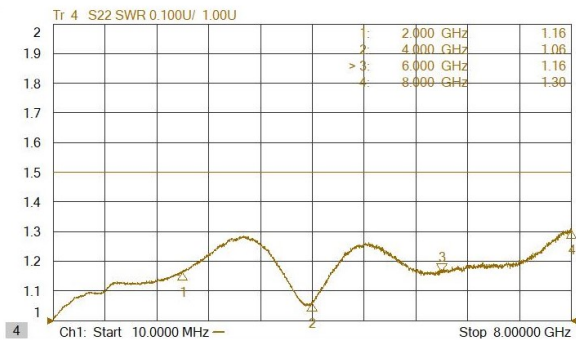
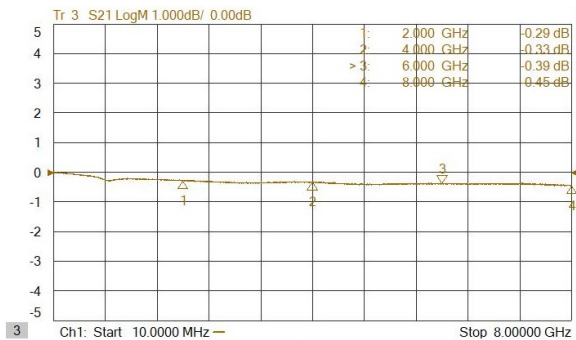
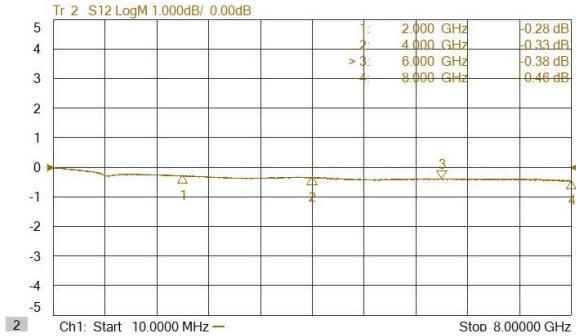
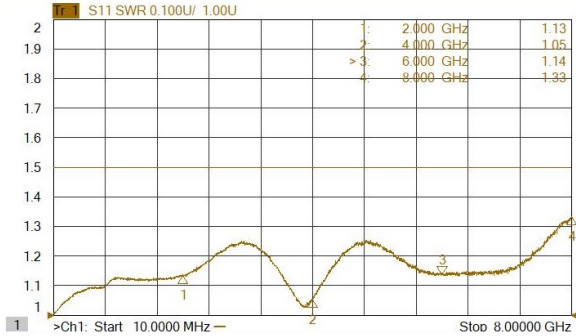

[CABLE FOR CONNECTION]

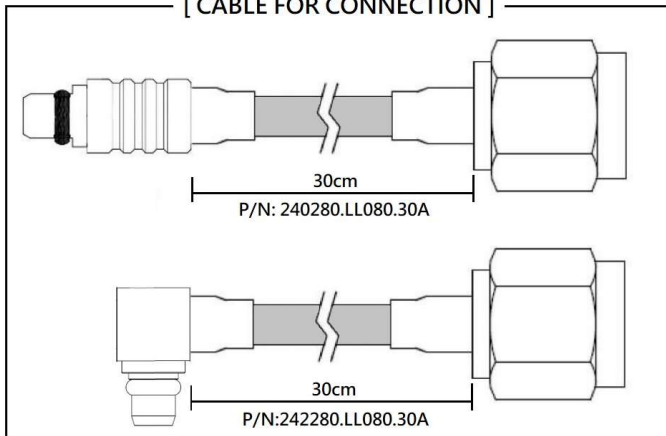

[MHF/U.FL TEST CONTACT]

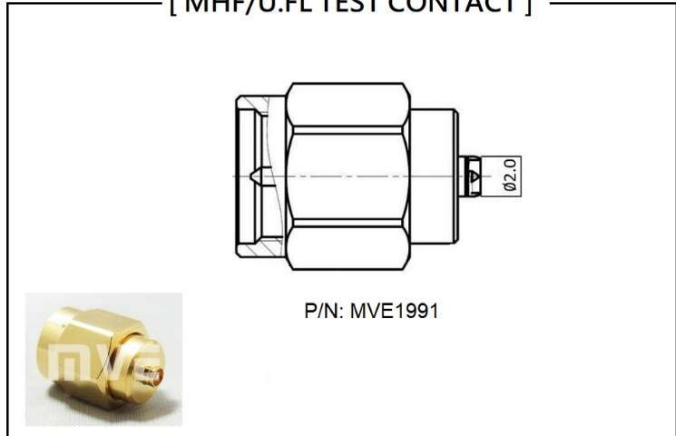

NOTES

1. ALL SPECIFICATIONS ARE SUBJECT TO CHANGE WITHOUT NOTICE AT ANY TIME
2. CUSTOMER OUTLINE DRAWING FOR REFERENCE ONLY